



**BAR KNOBS**

**THERMOPLASTIC**

Material- Call for material specifications

Insert- Brass

Projecting Stud- Steel, zinc plated

Hex Nut- Steel, zinc plated

† Insert- Steel, zinc plated

\* Insert- Aluminum



3081



3084



3088/3089 Thru Hole



3086



3087



3088/3094



3093



3096



2031



2031



2033



2020



2022

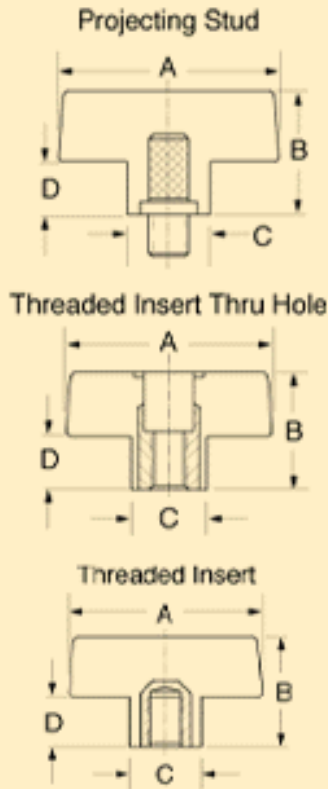

### Threaded Insert

Part No.	Insert	
	Thread	Depth
2031AB	8-32	3/8
2031CB	10-32	3/8
2031DC	1/4-20	1/2
2031FC	5/16-18	1/2
2031HC	3/8-16	1/2
2031KC	1/2-13	1/2

### Threaded Insert Thru Hole

Part No.	Insert	
	Thread	Depth
2031DK	1/4-20	1/2
2031DX	1/4-20	Hex Nut
2031FK	5/16-18	1/2
2031FX	5/16-18	Hex Nut
2031HK	3/8-16	1/2
2031HX	3/8-16	Hex Nut
<b>**Nylok locking feature</b>		

[← back](#)